



Industrial UPS Rack or Floor Mount

Series 1000 UPS Features

- True On-line Technology for Maximum Power Protection
- Input to Output Isolation
- True "Zero Break" Fully Rated Solid State Static Transfer Switch Standard
- Pure Sine Wave Output
- Transistor Power Block Technology
- Fast Recovery Battery Charger
- Less than 1% Total Harmonic Distortion
- Handles 5:1 Crest Factor Loads
- Redundant Fault Tolerant Circuitry
- Low Audible Noise
- Perfect For Office or Industrial Installations
- Mounts in Standard 19" or 23" Rack
- Front Access For Easy Installation and Service
- Seismic Zone 4 Construction
- User-Friendly Display
- 20-Year Design Life
- ANSI 61 Gray Powder Coat Finish
- Built to Meet UL1778, NEMA, NEC, ANSI and FCC Standards



Available Sizes:
3kW / 3.75kVA,
5kW / 6.25kVA,
7.5kW / 9.37kVA

OPTIONS

- ⇒ Multiple Voltage Outputs Available
- ⇒ 50Hz/60Hz Models
- ⇒ External Maintenance Bypass Switch
- ⇒ Floor Mount Kit
- ⇒ Form C Alarm Interface Contacts
- ⇒ Digital Meter Panel (Shown)
- ⇒ Customizable Designs for Unique Applications
- ⇒ Dual Input Kit

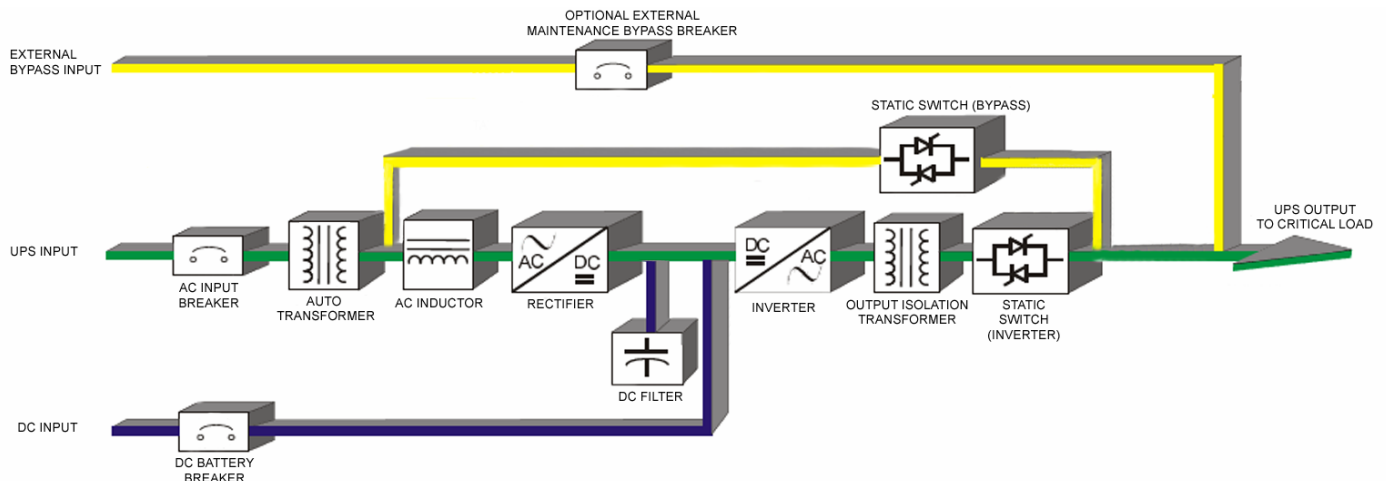



Industrial UPS Rack or Floor Mount

Technical Specifications			
MODEL	LT1030RM	LT1050RM	LT1075RM
Max. Output Power (Watts) (60Hz)	3,000	5,000	7,500
Max. Output Power (Watts) (50Hz)	2,400	4,000	6,000
INPUT			
Nominal Input Voltage (60Hz)	120, 208, 220, 240 VAC		
Nominal Input Voltage (50Hz)	220, 230, 240 VAC		
Input Voltage Range (50 & 60 Hz)	+15%, -25% (without using batteries)		
Input Frequency Range	45 - 65 Hz		
Power Walk-In	5 seconds to full load		
Input/Output Power Connections	Hardwire Connection Standard		
OUTPUT			
Nominal Output Voltage (60Hz)	120, 208, 220, 240 VAC		
Nominal Output Voltage (50Hz)	220, 230, 240 VAC		
Regulation	(Steady State): $\pm 1\%$ for all line and load conditions (Dynamic): $\pm 2\%$ from nominal for 100% load steps		
THD	Will not exceed 1% for linear loads and 3% for non-linear loads		
Frequency Stability	$\pm 0.01\%$ from nominal		
Sync. Window	$\pm 2\%$		
Maximum Load Crest Factor	$\pm 5:1$		
Slew Rate	1Hz / second maximum		
Harmonic Distortion	< 1% with linear load from .8 leading to .8 lagging power factor		
Overload Ratings @ 0.8 PF	110% - Indefinite, 125% for 10 min, 150% for 1 min		
Overload Ratings @ 1.0 PF	120% for 15 sec, 125% for 8 sec		
Surge Withstand	Passes IEEE 587 / ANSI CG2.41 Category A		
BATTERY			
	LT1030RM	LT1050RM	LT1075RM
Voltage (VDC)	120	120	120
DC Amps @ 100% Load	29	48.3	72.5
Recharge Time	< 1 hour to 90% charge level after complete discharge		
ENVIRONMENT			
Operating Temperature	32°F to 104°F (0°C to 40°C)		
Humidity	0 – 95% non-condensing		
Audible Noise	< 50 dB(A) Scale @ 1 meter		
Heat Rejection (@ 1.0 PF Load)	2,100 BTU / hr.	3,500 BTU / hr.	5,250 BTU / hr.
ENCLOSURE			
Dimensions inches (cm)	17"W x 18"D x 32.25"H (43W x 46D x 82H)		
Weight (lbs/kg)	290 / 132	310 / 141	335 / 152
Color	ANSI 61 Gray		
Ventilation	Forced Air : Intake – Rear Bottom, Exhaust – Rear Top		
Rating	NEMA1		
Cable Entry	Rear		

Note: All data is subject to change without notice.